

Remanufacturing in Electronics

*An Overview from the
Perspective of
Electronics Packaging*

by Norman Stockham and Andy Whitaker

Content

- TWI and interest
- Overview of remanufacturing issues
- Applications
- Special issues for electronics
- Some technical solutions
- Conclusions

- Independent R&T organisation
- Membership based
- Limited by guarantee
- Specialising in materials, joining, assembly, training & technology transfer
- 3500 industrial members in 75 countries
- £40M turnover
- 550 staff
- 40 years experience in electronic packaging

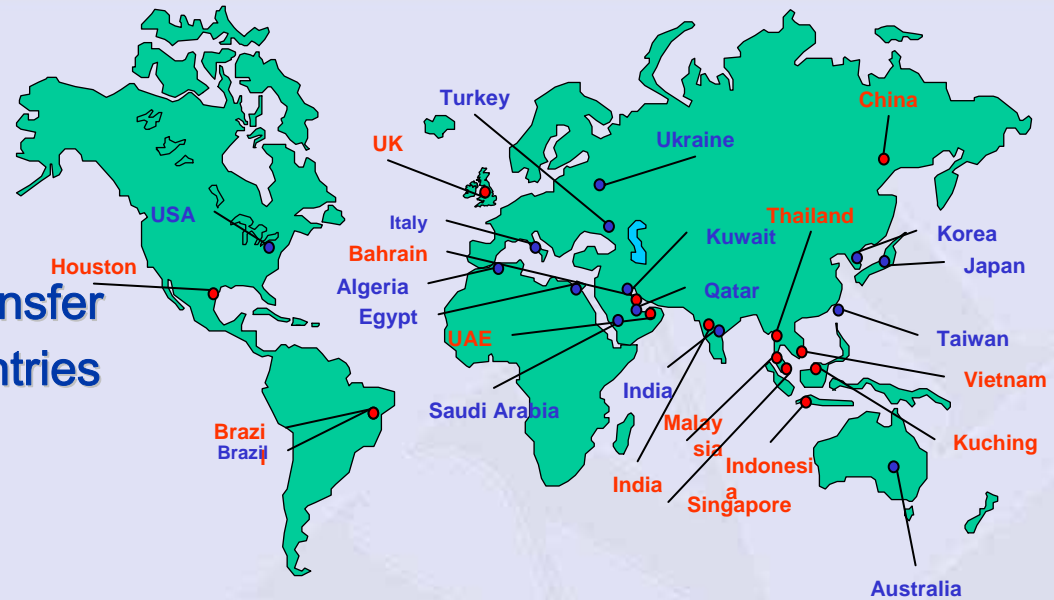

Global Presence
Facilities: Malaysia & Vietnam
Offices : 14 countries

4 UK Technology Centres



Cambridge



Middlesbrough



Sheffield



Port Talbot

Key Industry Sectors we Serve

Aerospace



Automotive



Construction



**Equipment,
Consumables & Materials**



Electronics



Medical



Oil & Gas



Power

Drivers for Remanufactured Electronics

- Monetary value
- Ethics – resources footprint
- Legislation - environmental impact
- Necessity – otherwise not available
- Fashion
 - +ve “Retro”
 - –ve “Out of style”



Remanufacturing Processes

- Collection
- Inspection & identification of faults
- Disassembly of product
- Cleaning & storage of parts
- Reconditioning of parts (replacement)
- Reassembly of product (special tools?)
- Testing to verify functioning as new product
- Identification

Re-Added Value – the facts of life

Remanufactured Sales Price

DEDUCT:

- User return costs (information, logistics)
- Sorting, storage, waste stream
- New Components
- Remanufacture Process
- Requalification
- Future supply chain (components, software and service....)
- Insurance liabilities
- Distribution, Sales and Marketing

↑
C
O
S
T
S
↓

= Bottom Line if +ve then 😊

General criteria for viable Remanufactured Electronics

- Products of high value – probably capital items
- Products with known service lifetime
- Reliability engineering support
- Intentionally Designed for Remanufacture for lower cost
- Component supply/recovery chain and obsolescence management in place
- Economies of scale- quantity, logistics, geography -> USA
- Export for higher relative value in developing markets

Opportunities for Remanufacturing Electronics

- Products with known shorter life components - electrolytics
- Some expensive components - processors
- Part of larger valuable products - building controls
- Can be damaged but salvageable - vehicles
- Upgrades of hardware and or software required – IT Servers
- Consumer items if easily cleaned, high volume, low build complexity
- Re-styling of consumer items
- Exploit WEEE legislation - provides incentives and routes

Current Examples of Remanufactured Electronics -1

- Volume Office Equipment
 - photocopiers
 - printers
- Civilian Motor vehicle upgrades
 - ignition and emission sensor control systems
 - drive train automation
- Military vehicles
 - eg Abrams MA1A2 MBT tank line
 - “common module” sensor systems



Current Examples of Remanufactured Electronics -2

- Military and Services portable communications
- Building and plant control systems
- IT Server upgrades
- Consumer products
 - Single use cameras
 - Mobile telephones (for secondary markets)
 - Laptops and PDAs (for secondary markets)
 - Set top boxes

Remanufactured Products on the Market – Amazon.com



Remanufactured Olympus W-10
Digital Voice Recorder with Built-in
Digital Camera
Buy new:–\$28.45



Remanufactured Sennheiser RS100 Wireless
Headphones1
Used & new from \$65.54



Remanufactured Rio Forge
256 MB MP3 Player1 Used &
new from \$55.62



Remanufactured Nikon Coolpix 4800 4MP
Digital Camera
Used & new from \$279.00



Remanufactured Dell Latitude C640
Notebook
Used & new from \$449.00



Remanufactured InFocus SP5000
ScreenPlay Home
Theater Projector1 Used & new
from \$799.85



Refurbished Photosmart HP
PSC1610 Printer1
Used & new from \$114.73



Remanufactured Teac CD-X6 Wall-Mountable
Stereo
Used & new from \$59.95

Japan - Inverse Manufacturing

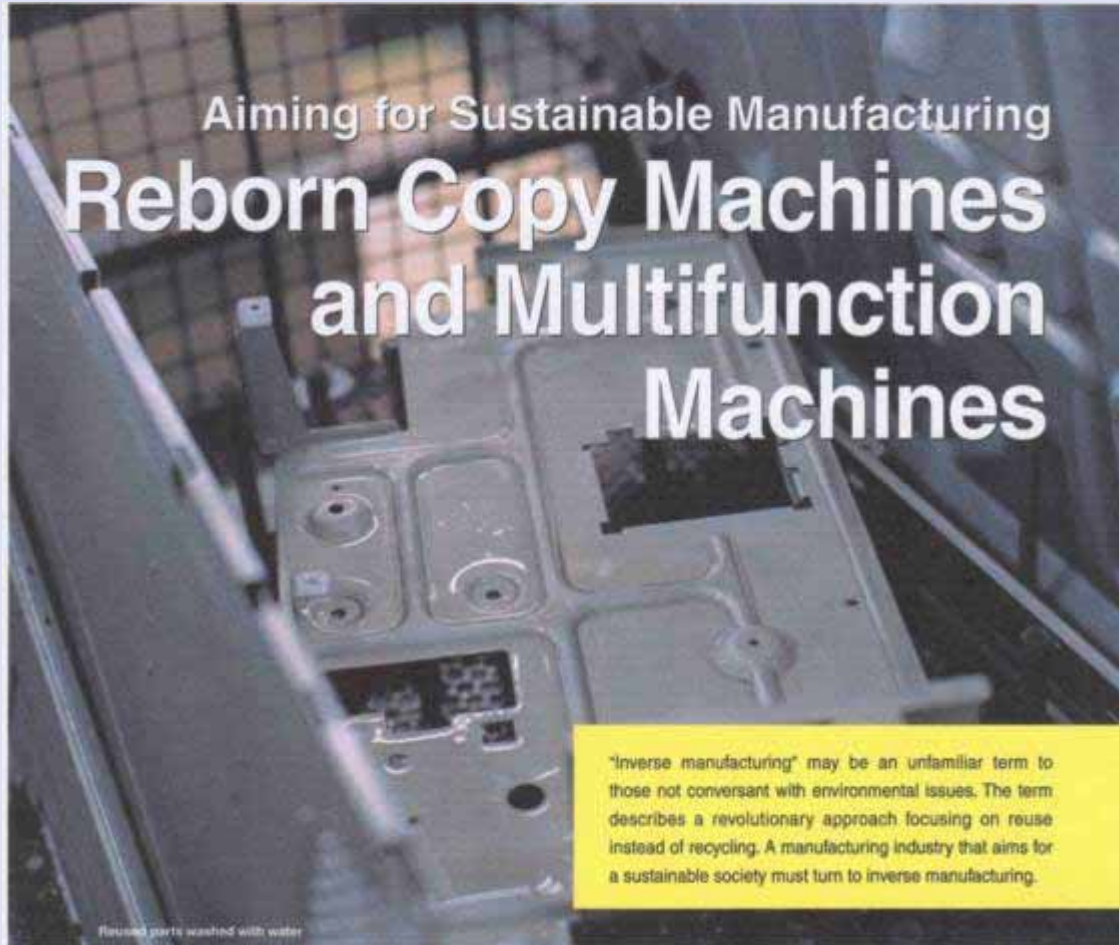

Fuji Xerox
copy machines:

- Leased
- Modular design for flexible upgrade
- Zero landfill

World EMS Rework/Repair Market***

| Year | Revenues |
|------|----------|
| 1999 | \$1.9 Bn |
| 2003 | \$4.0 Bn |
| 2009 | \$14.0Bn |

“OEMs expected to continue their drive to reduce costs and requirement for outsourced remanufacturing & repair services”

*Electronic Manufacturing Service (EMS) Providers

**Source: Frost & Sullivan

Special issues for Electronics Complexity

- Multiple electrical connections
- Increasingly thermal connections
- Possibly optical connections
- Highly resilient coatings/hermetic packages
- Multiple assembly technologies in one product
- Trend is even higher density – less accessibility
 - Flip chip and CSP with adhesive underfills
 - Embedded passives (eg ADEPT programme)

Special issues for Electronics

Lead-free Solders

- RoHS type legislation has produced a transition
- Legacy of products with leaded solders
- New lead-free solders may require higher temperatures
- Possible mixed-solder regimes with un-quantified performance
- New plated finishes on components

Special issues for Electronics Original Design

- Most products are not designed for remanufacture
- Many products have a short “design” life
- Very fast technology development – massive obsolescence
- Insufficient precise knowledge of electronic device life

Solutions Required for Electronics

- Design for Disassembly (D4D)
- Non Destructive Testing
- Component recovery
- Re-Assembly methods
- Module partitioning
- Design for Test
- Lower cost Reliability prediction and test

What is “Design for Disassembly”?

- Designing joints in products to withstand all rigours of operation, but at end of life can be taken apart quickly and cheaply

Also called:

- Inverse manufacture (Japan)

Design for Disassembly Shape Memory Polymers

- Standard polymers including ABS, PC, ABS/PC blend and PET may be processed to give highly effective shape memory properties
- Standard manufacturing methods may therefore be used to produce self disassembling products
- Hot liquid or hot air used to trigger shape recovery



Design for Disassembly Shape Memory Polymer Fasteners

First commercially available
shape memory polymer
fasteners developed by
Mitsubishi Heavy Industries.

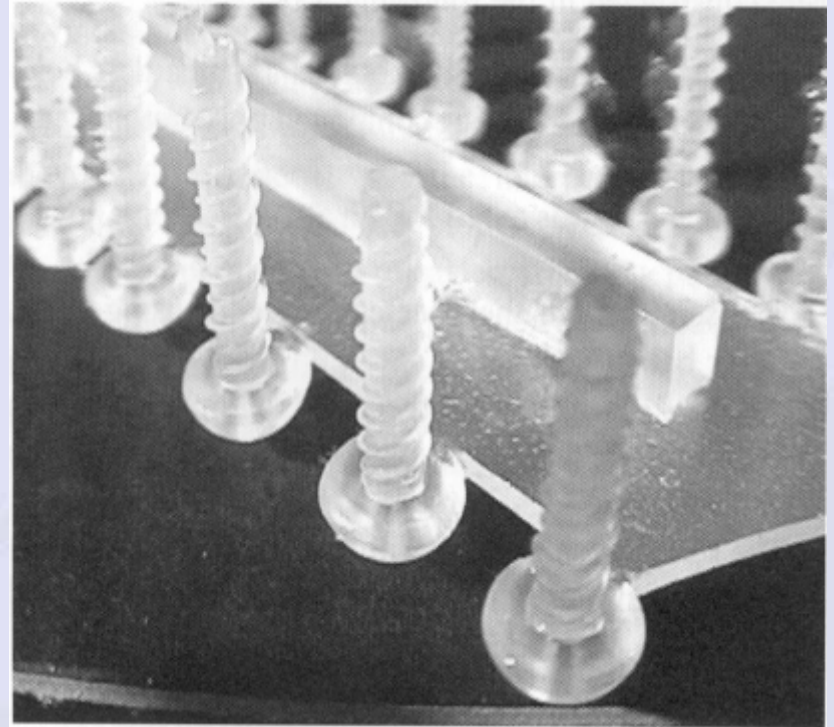

Design for Disassembly

Active Disassembly using Active Fasteners

- Self Disassembling Products:
- Smart actuators or releasable fasteners in products produce disassembly when triggered at the end of product life
- Allows production of high purity, pre-defined fractions, ready for recycling.



18 active fasteners allowed all the components of this Sony Playstation to automatically disassemble.

Design for Disassembly

Thermal Polymer Clips – D4D

Portable comms
device packaged
with thermally
releasable clips



Non Destructive Testing

Automated multi-method MICROSCAN

In-line rapid assessment for diagnostics including:

- Real time micro focus X-ray tomography
- Surface Acoustic Microscopy
- Optical Image Analysis
- Thermal imaging
- High frequency ultrasonics
- Laser Thermal Pulse analysis

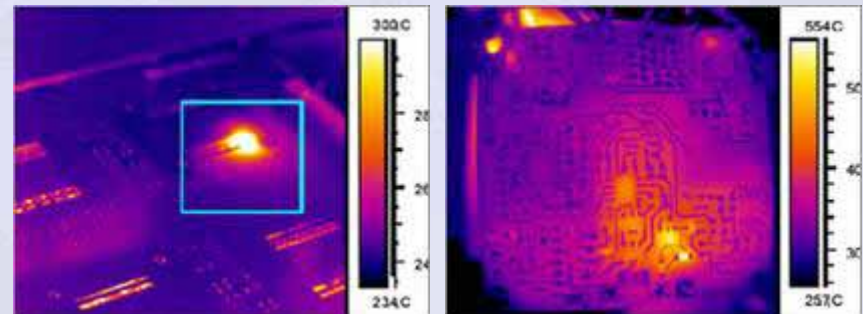
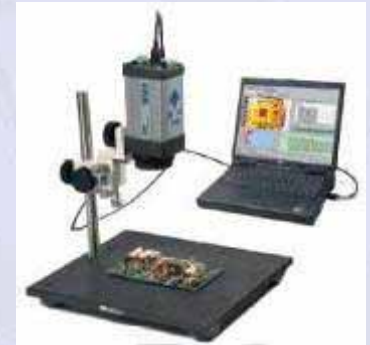

Component Recovery Using Ionic Liquids - HIPERPOL

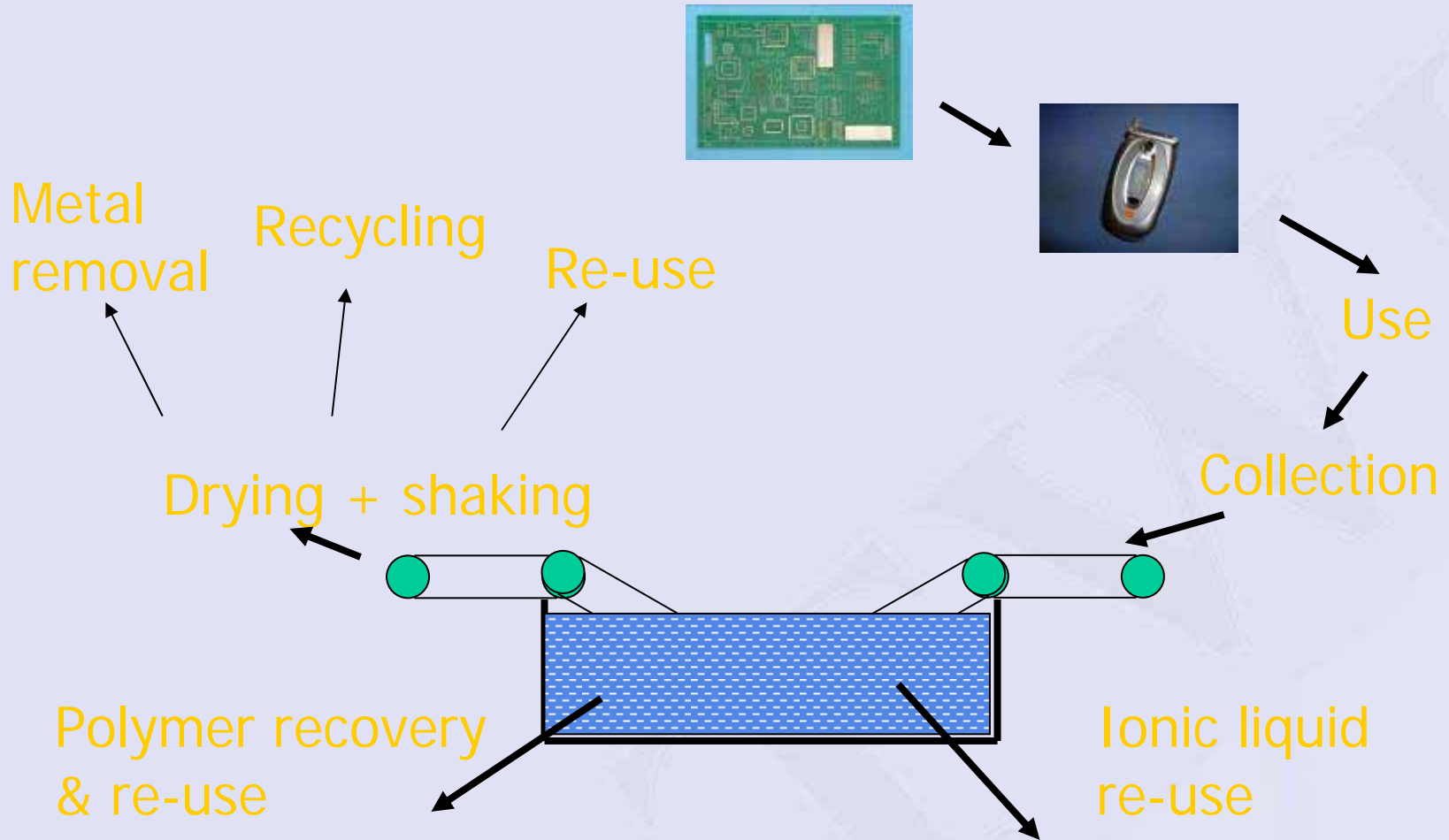

Component Recovery

Chemical Breakdown – PCB and Solder

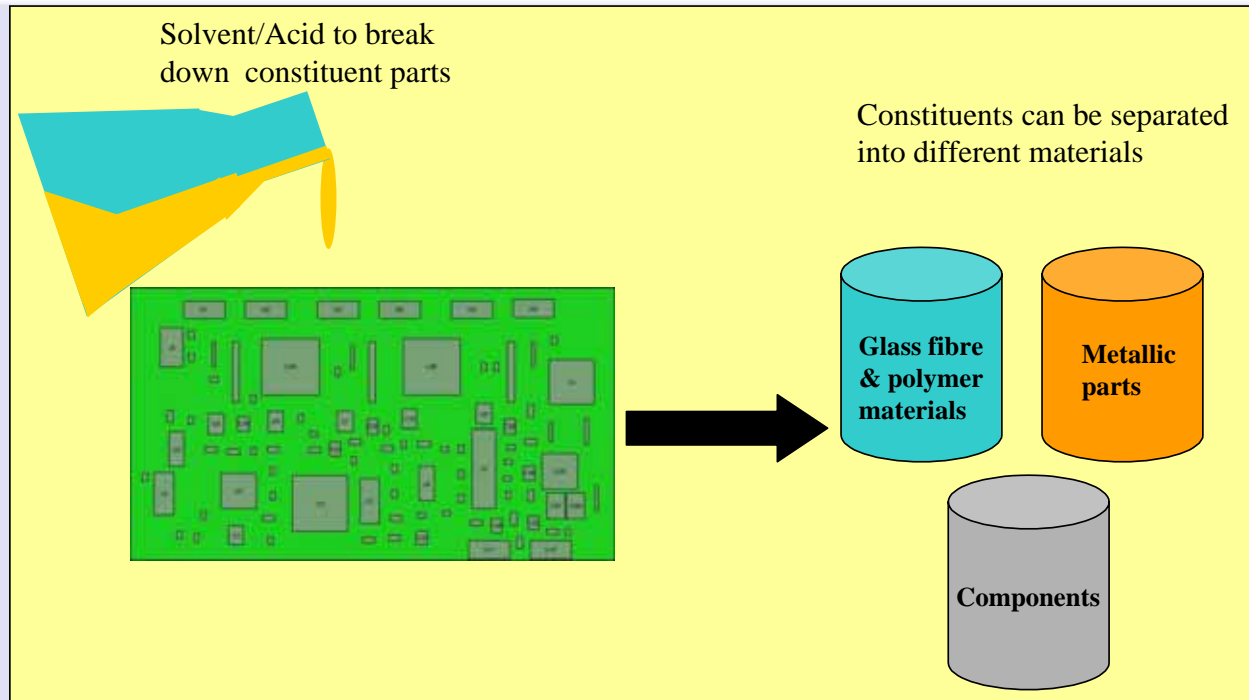

Advantages: Often no additional energy required, full immersion, can be material selective

Disadvantages: H&S, volatile and toxic solvents, disposal, treatment of solvent to recover material

Component Recovery Biodegradation - BIOSORT

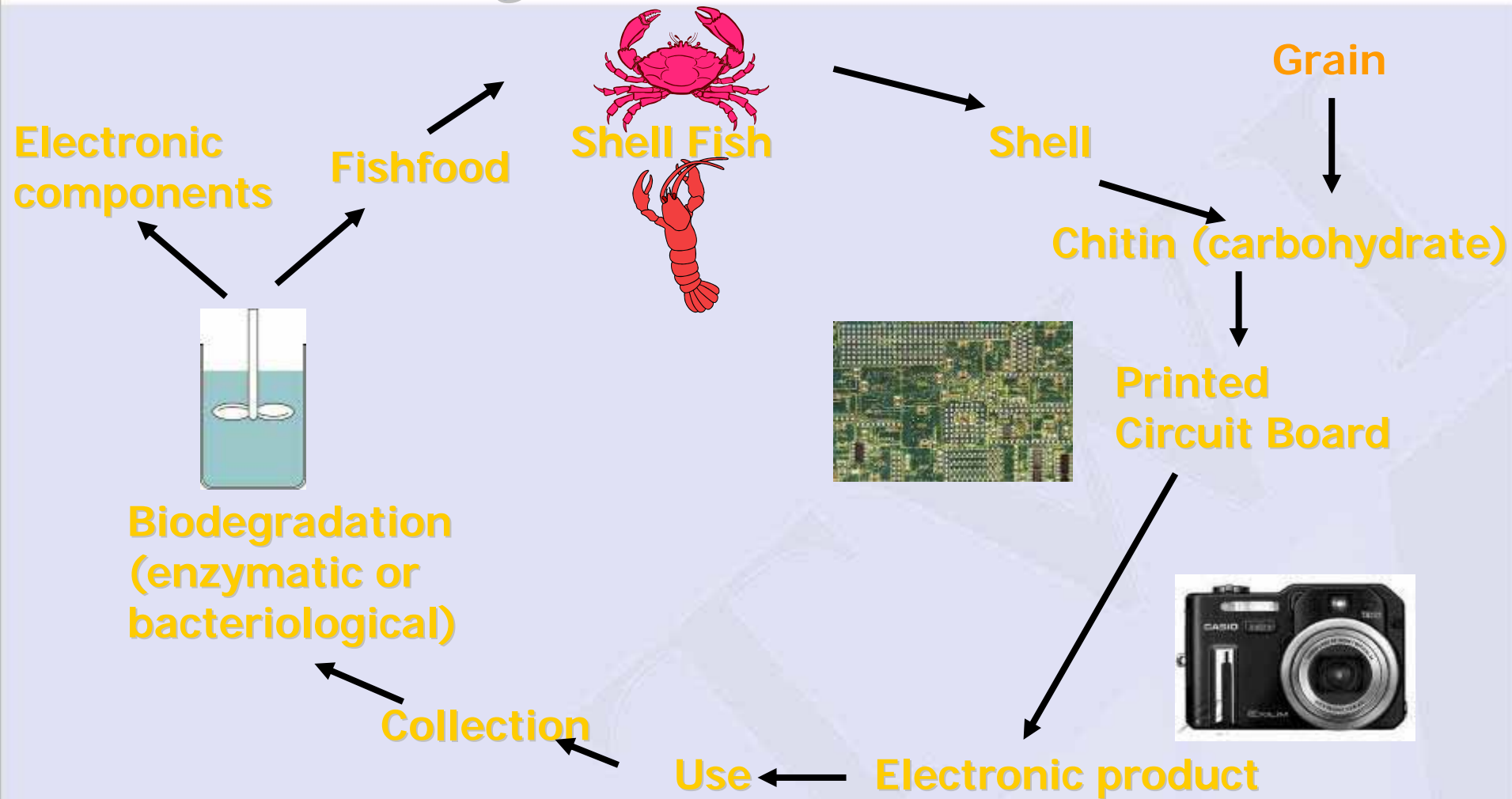

Re-Assembly Method

Surfisculpt™ Metallic “Velcro”

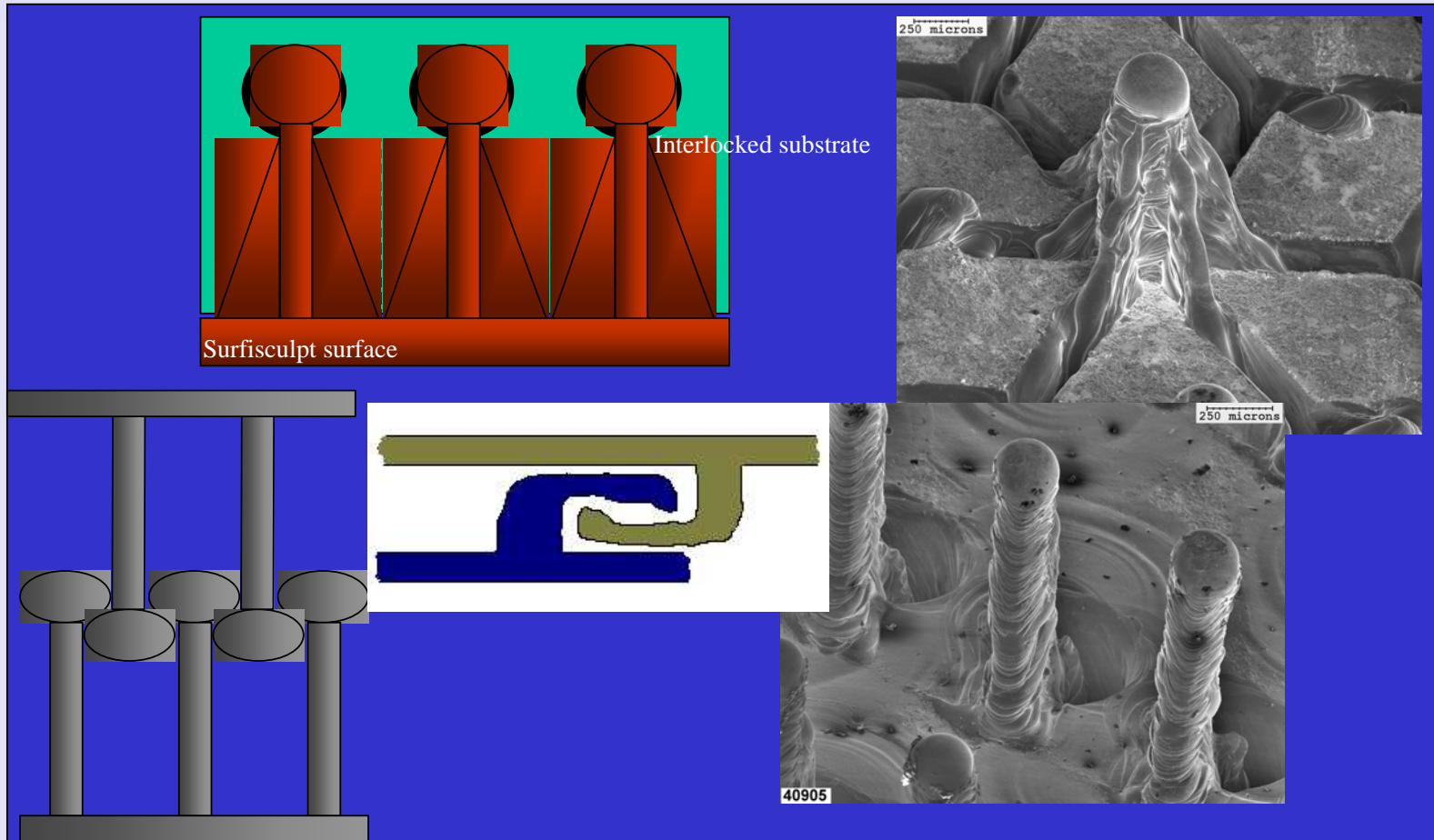

Re-Assembly Method

Micro Friction Stir Welding - μ FSW ©

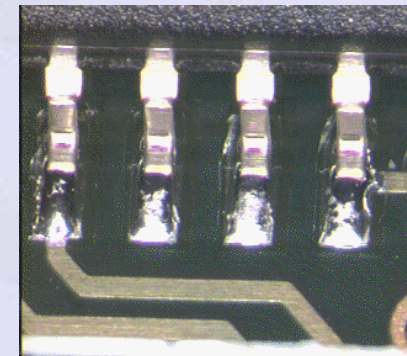
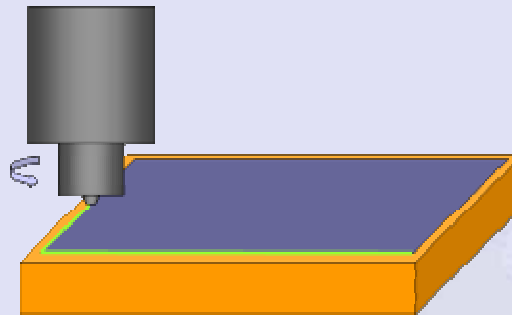
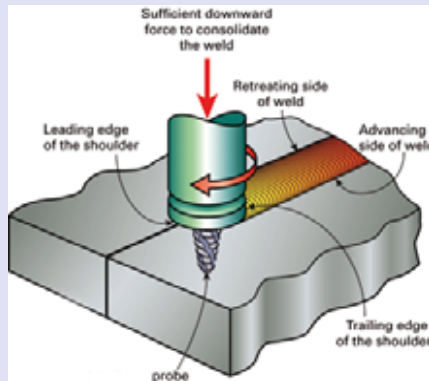

Precision heat input allows fluxless soldering and welding from one side of metals and polymers for re-sealing packages and forming electrical and thermal connections

Re-Assembly Method

Laser Soldering

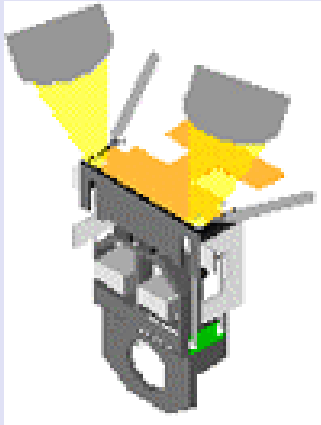

Wire Soldering



PANASONIC
SOFTBEAM LD
Laser Diode
Micro soldering system

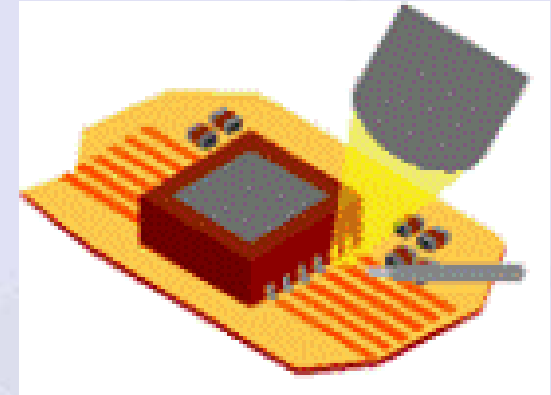

FPC and CCD Soldering

Precision heat input allows soldering without affecting the reliability of surrounding components

Module Partitioning for Residual Value

- Important to maximise residual value reclaimed
- Modular construction assists remanufacturing
- Modules **increase original cost** – packaging and connectors
- Present methods partition electronics mainly by function
- Remanufacturing also requires **partitioning by lifetime**
- Requires component level lifetime prediction tools

Lifetime Reliability Prediction -CALCE PWA™ Virtual Qualification (VQ) Process

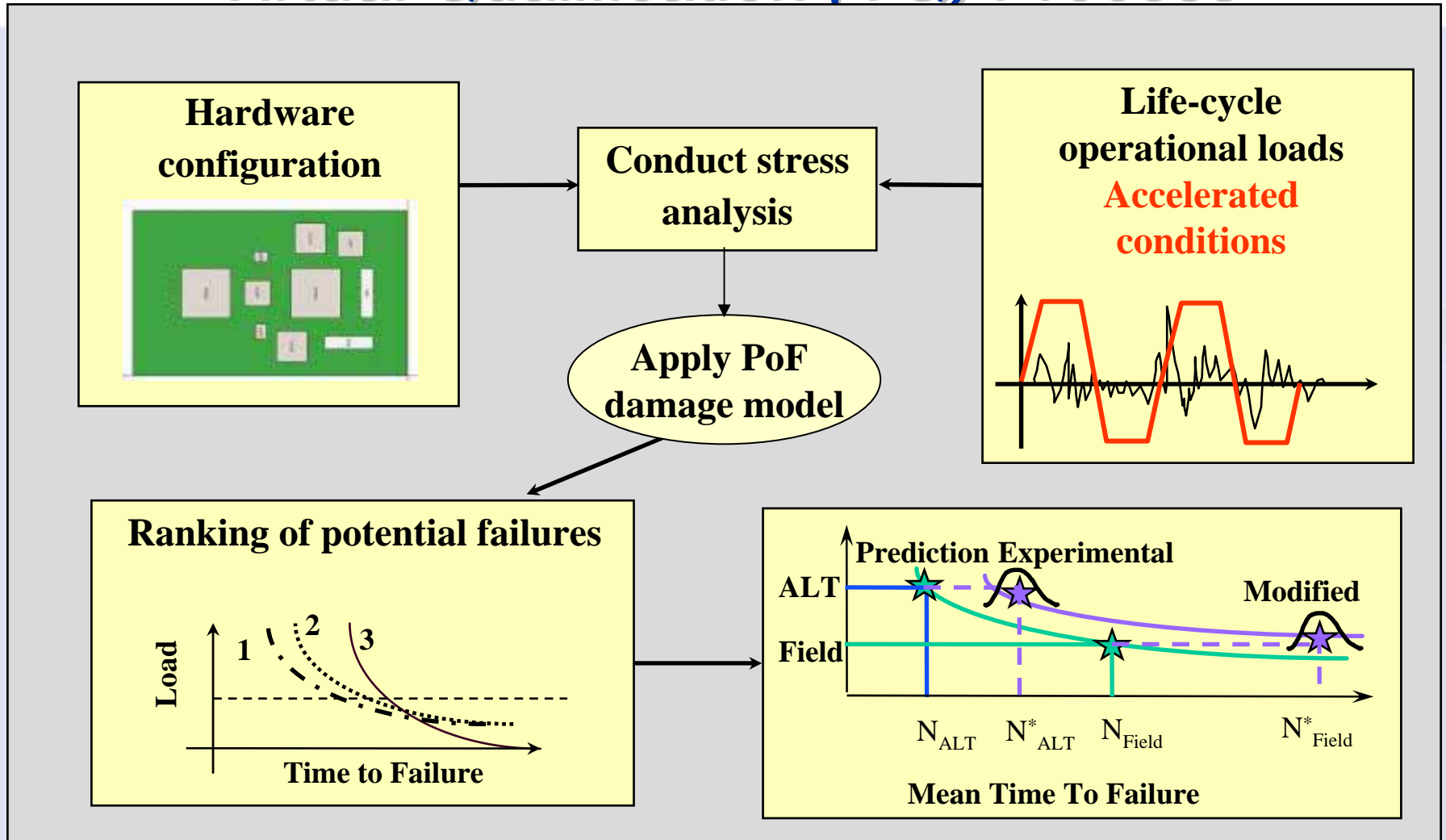

Lifetime Reliability Prediction -CALCE PWA™ Stress Models

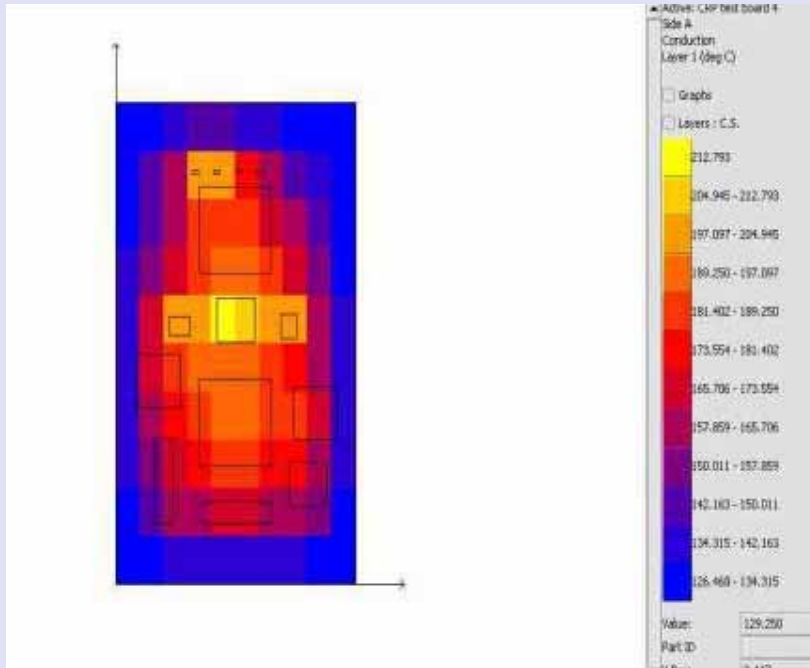

Thermal analysis

Mechanical analysis

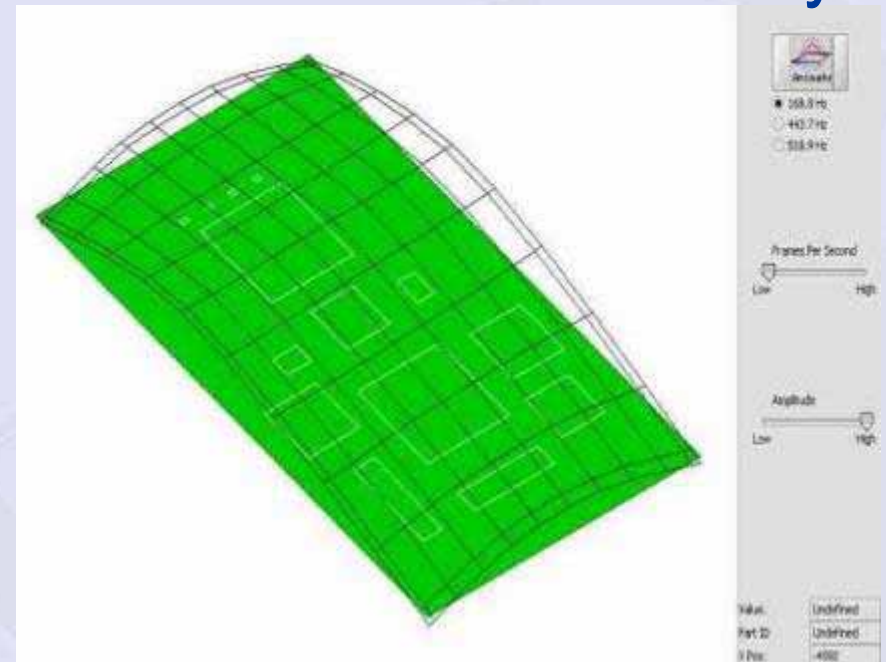

Reliability Assessment

Precision Reliability

- Rapid detection of early onset failure during accelerated tests
- Advance warning without full “1000hr functional failure” type test
- Precise temperature control, $\pm 0.01^{\circ}\text{C}$
- Precise in-situ measurement, e.g. $\pm 0.1\mu\Omega$ resistance
- Example: Joint degradation during thermal cycling

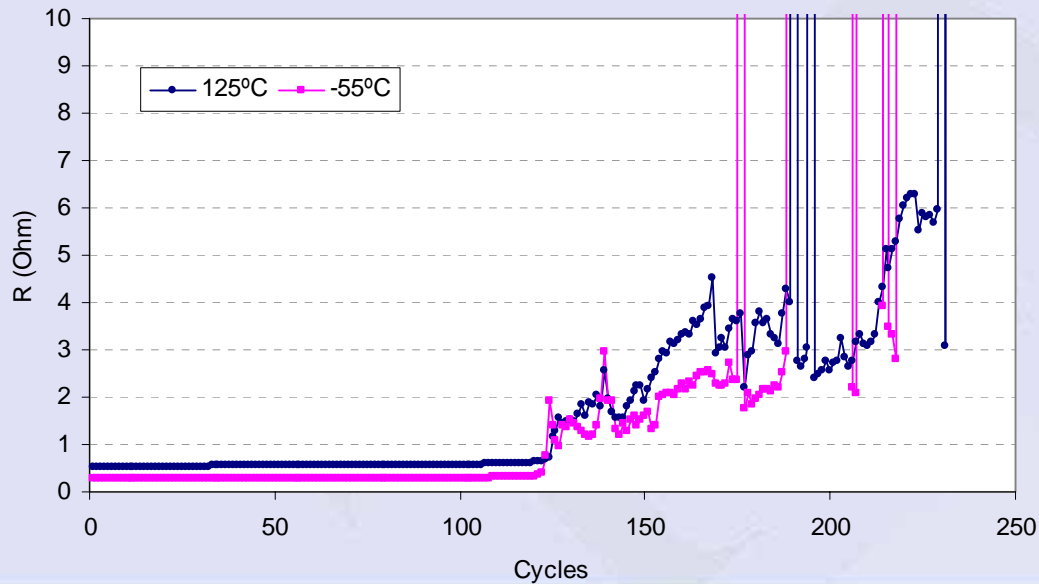

Remanufacturing of Electronics

Conclusions

- Important technology to achieve world resource utilisation
- State of definition and development is variable worldwide
- Electronics has special issues due to complexity
- There are new diagnostic, process and reliability test methods becoming available
- Requires component level lifetime prediction tools and data

Contact Details

Andy Whitaker – Section Manager Microtechnology
Norman Stockham – Business Development Manager

TWI Ltd.
Granta Park
Great Abington
Cambridge
Cambridgeshire
CB21 6AL UK

Tel: +44 (0)1223 899000

Fax: +44 (0)1223 891284

E-mail: microtechnology@twi.co.uk

Web: www.twi.co.uk

